

1. 製品名称／PRODUCT NAME : SPOT-ON 2.0 W/B DUAL ROW SMT REC HSG

製品番号／PART NUMBER : 2011962**☆

(**は極数を示し、☆は色を示す。図面参照。)

(** IS CIRCUITS SIZE.☆ IS COLOR. REFER TO DRAWING.)

2. 標準梱包数／STANDARD PACKAGING QUANTITY

極数 CKT. SIZE	プラスチックトレイ(9列) PLASTIC TRAY (9 ROWS)	内装カートン PRIMARY CARTON		外装カートン SHIPPING CARTON
	1トレイ製品数 QTY. IN ONE TRAY	トレイ枚数 NUMBER OF TRAYS	製品数 QUANTITY	製品数(内装カートン×2) QUANTITY (PRIMARY CARTON X2)
10	195	16	3,120	6,240
12	170	16	2,720	5,440
14	150	16	2,400	4,800
16	135	16	2,160	4,320
18	125	16	2,000	4,000
20	115	16	1,840	3,680
22	100	16	1,600	3,200
24	95	16	1,520	3,040
26	90	16	1,440	2,880
28	90	16	1,440	2,880
30	80	16	1,280	2,560
32	70	16	1,120	2,240
34	70	16	1,120	2,240
36	70	16	1,120	2,240
38	60	16	960	1,920
40	60	16	960	1,920

REV.	C		
SHEET	1~2		
REVISE ON PC ONLY		TITLE:	
C	REVISED 122797 2017/10/02 Y.TOKUZONO	2011962***梱包仕様書 SALES PACKAGING SPEC. FOR 2011962***	
	THIS DOCUMENT CONTAINS INFORMATION THAT IS PROPRIETARY TO MOLEX ELECTRONIC TECHNOLOGIES, LLC AND SHOULD NOT BE USED WITHOUT WRITTEN PERMISSION		
REV.	DESCRIPTION		
DESIGN CONTROL J	STATUS	WRITTEN BY: YTOKUZONO	CHECKED BY: K.TAKAHASHI
		APPROVED BY: M.SASAO	DATE: 2017/03/13

DOCUMENT NUMBER 2011969200	DOC. TYPE PS	DOC. PART 200	CUSTOMER GENERAL	SHEET 1 OF 2
-------------------------------	-----------------	------------------	---------------------	-----------------

3. カートン外形参考寸法 / CARTON OUTER DIMENSIONS (REFERENCE PURPOSE ONLY) 単位 / UNIT: mm

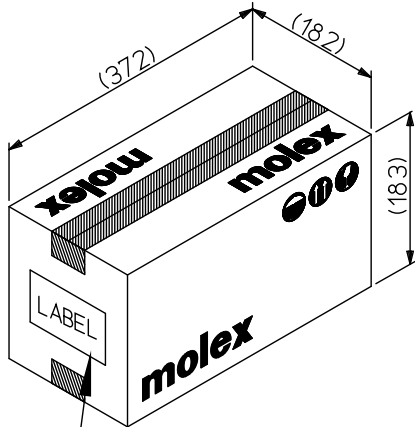

現品票
PART IDENTIFICATION LABEL
(製品型番, 数量, ロットNO. 表示)
INDICATION OF PART No., QUANTITY, LOT No.

内装カートン
PRIMARY CARTON

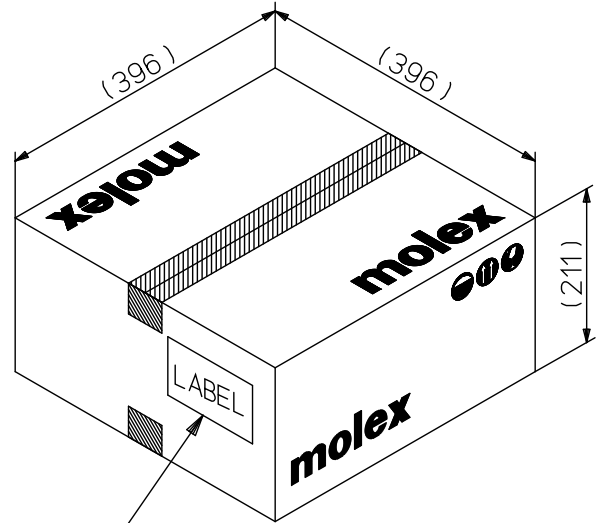

カートンラベル
CARTON LABEL
(製品型番, 数量, ロットNO. 表示)
INDICATION OF PART No., QUANTITY, LOT No.

外装カートン
SHIPPING CARTON

REVISE ON PC ONLY		TITLE:			
C	SEE SHEET 1 OF 2	2011962*** 梱包仕様書 SALES PACKAGING SPEC. FOR 2011962***			
	REV.	DESCRIPTION	THIS DOCUMENT CONTAINS INFORMATION THAT IS PROPRIETARY TO MOLEX ELECTRONIC TECHNOLOGIES, LLC AND SHOULD NOT BE USED WITHOUT WRITTEN PERMISSION		
DOCUMENT NUMBER 2011969200		DOC. TYPE PS	DOC. PART 200	CUSTOMER GENERAL	SHEET 2 OF 2