

THIS DRAWING IS UNPUBLISHED. RELEASED FOR PUBLICATION
 © COPYRIGHT - By - ALL RIGHTS RESERVED.

LOC	DIST	REVISIONS					
		P	LTR	DESCRIPTION	DATE	DWN	APVD
-	-		A1	REVISED PER ECO-11-005150	21MAR11	RK	HMR

8. PART NUMBER INFORMATION

CONNECTOR	TE CONNECTIVITY PART NUMBER	ELCON PART NUMBER	TERMINATION TYPE	PC TAIL LENGTH DIM "A"	RECOMMENDED MOUNTING BOARD	MATING BOARD
SOCKET	6650384-1	286-0052-12101	SOLDER TAIL (SHORT)	3.56 [.140] 2.54 [.100]	1.6 [.062] THICK	1.6 [.062] THICK
SOCKET	6650384-2	286-0052-11301	SOLDER TAIL COMPLIANT	5.08 [.200] 4.06 [.160]	3.2 [.125] OR THINNER	1.6 [.062] THICK
SOCKET	6650384-3	287-0032-12301	SOLDER TAIL (STANDARD)	5.08 [.200] 4.06 [.160]	3.2 [.125] OR THINNER	1.6 [.062] THICK

NOTES: UNLESS OTHERWISE SPECIFIED;

1. PART NUMBER CHANGES AND OR DESIGN CHANGES AFFECTING ITEM INTERCHANGEABILITY REQUIRE PRIOR ELCON APPROVAL AND AUTHORIZATION BY REVISION TO THIS DRAWING.

2. MATERIALS:

INSULATORS: THERMOPLASTIC, GLASS REINFORCED, COLOR-BLACK, UL94V-0 FLAMMABILITY RATED.

CONTACTS: PHOSPHOR-BRONZE ALLOY.

3. FINISHES:

CONTACTS: SELECTIVE GOLD PLATE PER MIL-G-45204 TYPE II, GRADE C, CLASS 0. 000030" MIN. THK, OVER NICKEL PER QQ-N-290, CLASS 2, .000040" MIN. THICKNESS.

TERMINALS: TIN PLATED, MATTE FINISH, .000100" MINIMUM THICKNESS.

4 SOCKETS ACCEPT 1.6 [.062] ± 10% THK PC BOARD.

5 EXAMPLE PCB CONFIGURATION.

6 THIS 3 X 2 SEGMENT CONFIGURATION SHOWN IS FOR REFERENCE ONLY. COMBINATION OF MULTIPLE NUMBERS OF 2 AND 3 SEGMENT MODULES COULD BE USED PER USER PREFERENCE. OVERALL COMBINATION SHOULD NOT EXCEED 8" IN LENGTH.

7 ITEMS PROVIDED TO THIS SPECIFICATION TO BE PERMANENTLY IDENTIFIED PER THE FOLLOWING IDENTIFIER:

YEAR WEEK

ELCON PART NO. & REV DATE CODE (e.g. 0505)

XXX-XXXX-XXXXX [] XXXX

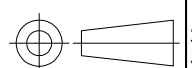
THIS DRAWING IS A CONTROLLED DOCUMENT.		DWN R. F. A. 01/05/05	 TE Connectivity		
DIMENSIONS: mm[INCHES]		CHK -			
		TOLERANCES UNLESS OTHERWISE SPECIFIED:		SOCKET CONNECTOR, CROWN EDGE	
		0 PLC ± - 1 PLC ± 0.5[0.020] 2 PLC ± 0.25[0.010] 3 PLC ± - 4 PLC ± - ANGLES ± 0.5°		6 POSITION POWER, STRAIGHT	
MATERIAL -		FINISH -		PN: 286-0052-1**01A	
		APVD D. CHAU 01/06/05		PRODUCT SPEC	
		APPLICATION SPEC		SIZE CAGE CODE DRAWING NO RESTRICTED TO	
		WEIGHT -		A3 00779 C-6650384	
		CUSTOMER DRAWING		SCALE 2:1 SHEET 1 OF 5 REV A1	

THIS DRAWING IS UNPUBLISHED. RELEASED FOR PUBLICATION
 © COPYRIGHT - By - ALL RIGHTS RESERVED.

LOC	DIST	REVISIONS					
		P	LTR	DESCRIPTION	DATE	DWN	APVD
-	-	-	-	SEE SHEET 1	-	-	-

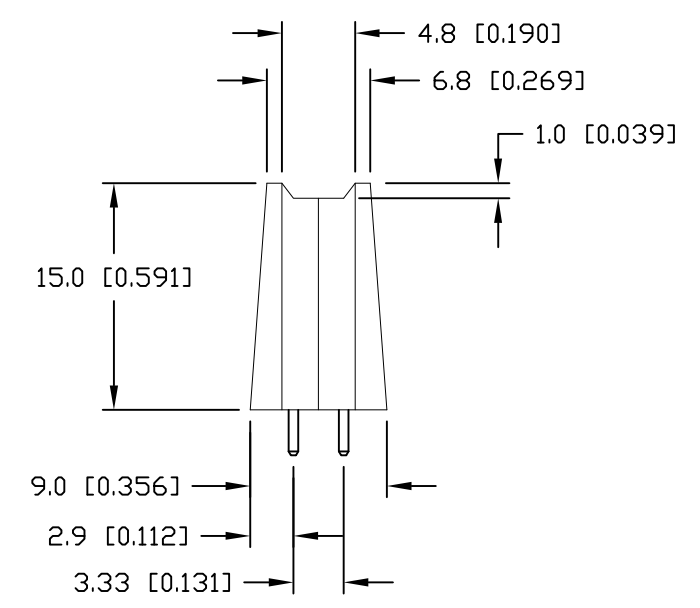
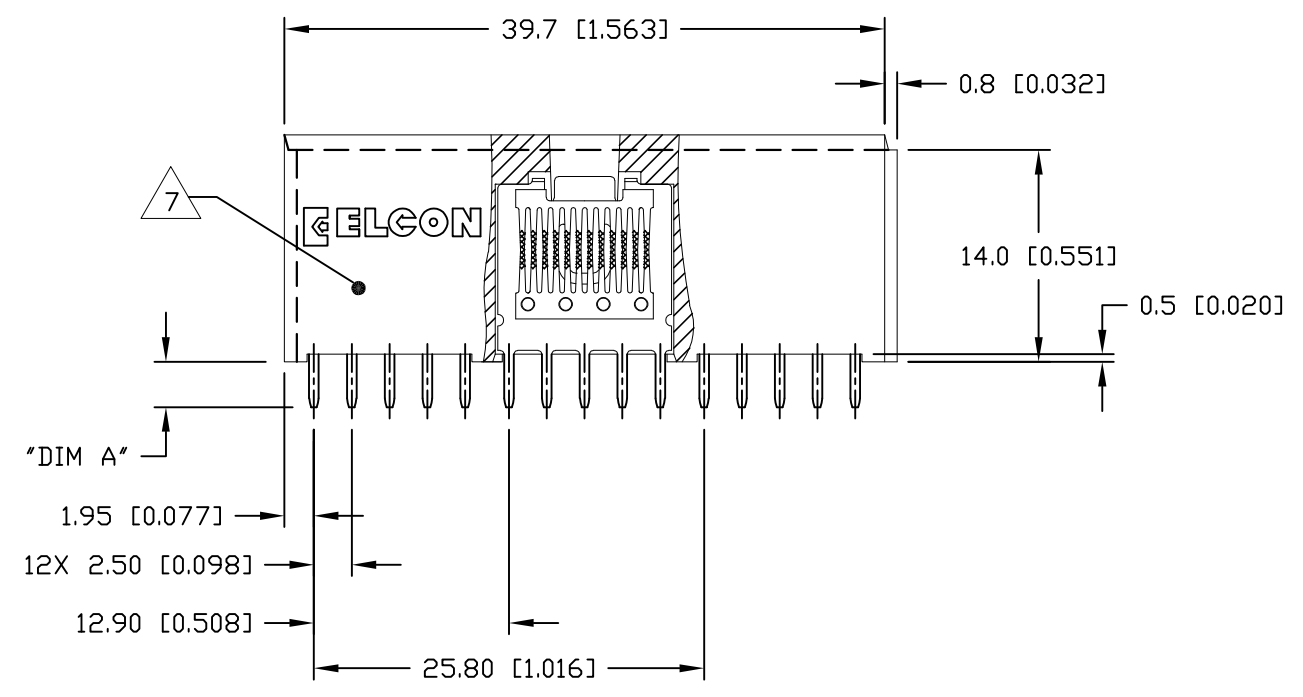
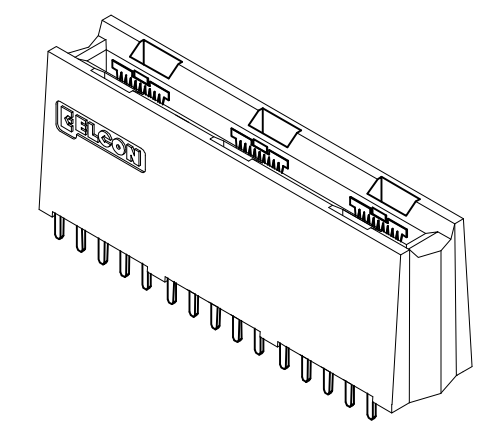
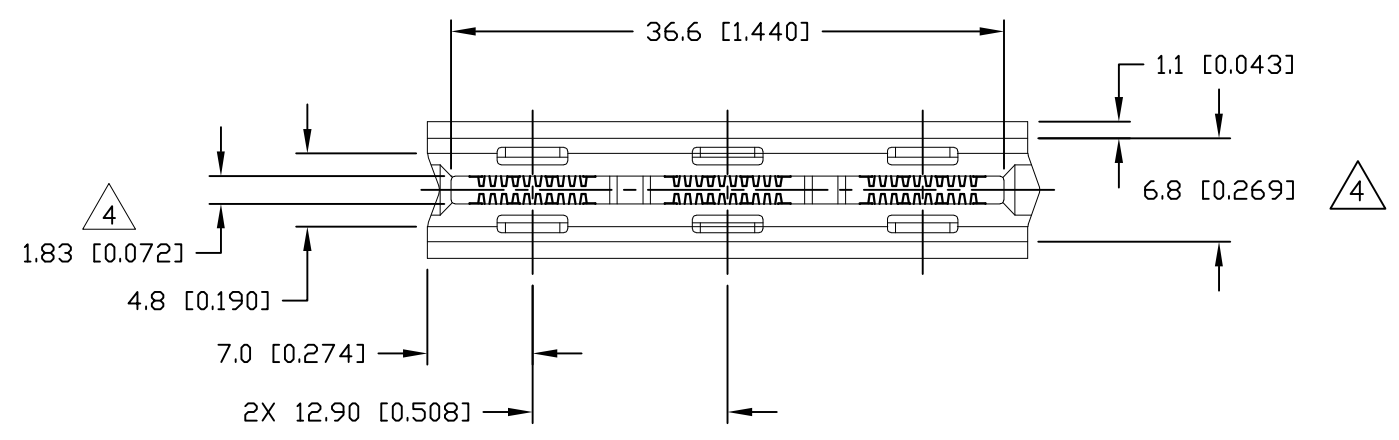

THIS DRAWING IS A CONTROLLED DOCUMENT.		DWN R. F. A.	01/05/05	 TE Connectivity					
DIMENSIONS: mm[INCHES]		CHK -	-						
TOLERANCES UNLESS OTHERWISE SPECIFIED:		APVD D. CHAU	01/06/05	NAME					
0 PLC ± - 1 PLC ± 0.5[0.020] 2 PLC ± 0.25[0.010] 3 PLC ± - 4 PLC ± - ANGLES ± 0.5°		PRODUCT SPEC		SOCKET CONNECTOR, CROWN EDGE 6 POSN POWER, STRAIGHT, SOLDER TAILS PN: 286-0052-12101A					
MATERIAL		FINISH		APPLICATION SPEC	SIZE	CAGE CODE	DRAWING NO	RESTRICTED TO	
-		-		-	A3	00779	C-6650384	-	
CUSTOMER DRAWING				WEIGHT	-	SCALE 2:1		SHEET 2 OF 5	REV A1

THIS DRAWING IS UNPUBLISHED. RELEASED FOR PUBLICATION
 © COPYRIGHT - By - ALL RIGHTS RESERVED.

LOC	DIST	REVISIONS					
		P	LTR	DESCRIPTION	DATE	DWN	APVD
-	-	-	-	SEE SHEET 1	-	-	-

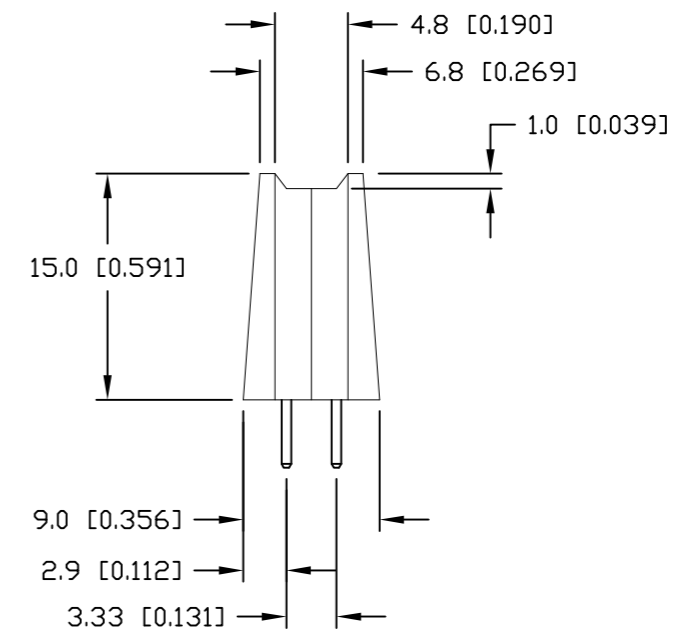
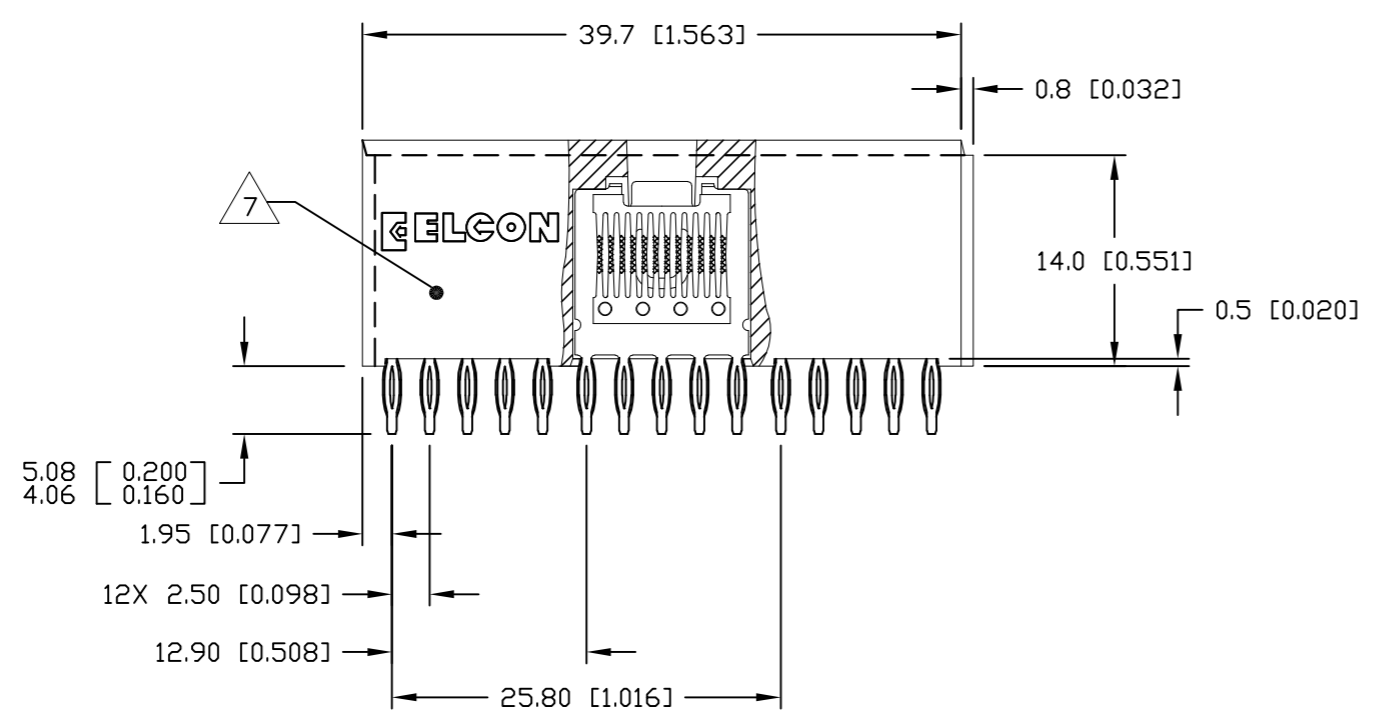
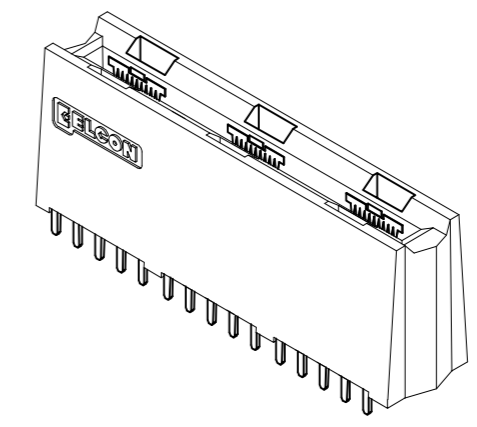
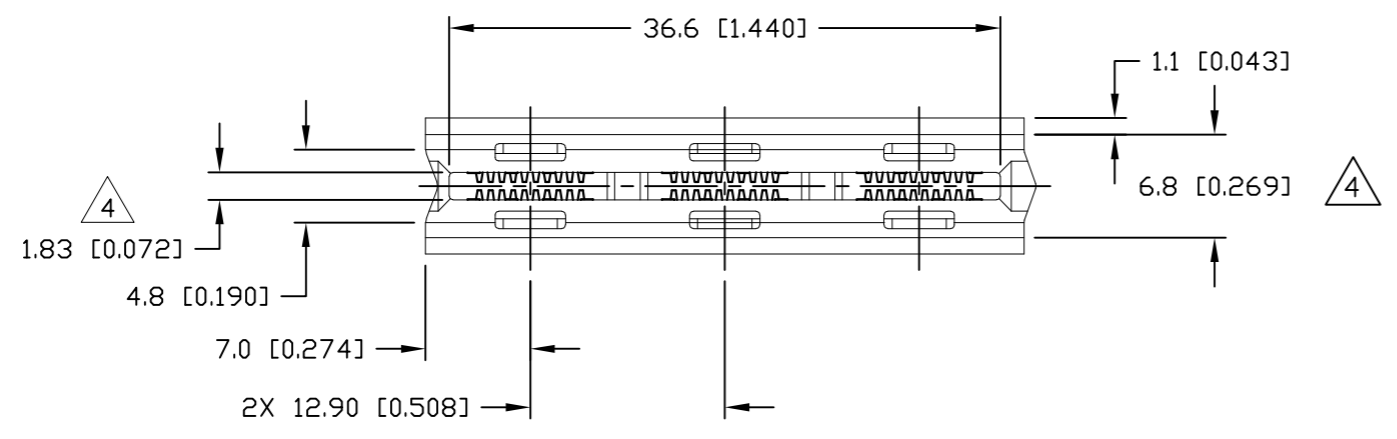

THIS DRAWING IS A CONTROLLED DOCUMENT.		DWN R. F. A.	01/05/05	 TE Connectivity	
DIMENSIONS: mm[INCHES]		CHK -	-		
TOLERANCES UNLESS OTHERWISE SPECIFIED:		APVD D. CHAU	01/06/05	NAME	
0 PLC ± - 1 PLC ± 0.5[0.020] 2 PLC ± 0.25[0.010] 3 PLC ± - 4 PLC ± - ANGLES ± 0.5°		PRODUCT SPEC		SOCKET CONNECTOR, CROWN EDGE 6 POSN PWR, STRAIGHT, COMPLIANT TAILS PN: 286-0052-11301A	
MATERIAL		FINISH		SIZE	RESTRICTED TO
-		-		A3	-
		WEIGHT		CAGE CODE	DRAWING NO
		-		00779	6650384
CUSTOMER DRAWING				SCALE	SHEET
				2:1	3 of 5
				REV	A1

THIS DRAWING IS UNPUBLISHED. RELEASED FOR PUBLICATION
 © COPYRIGHT - By - ALL RIGHTS RESERVED.

LOC	DIST	REVISIONS			
P	LTR	DESCRIPTION	DATE	DWN	APVD
-	-	SEE SHEET 1	-	-	-

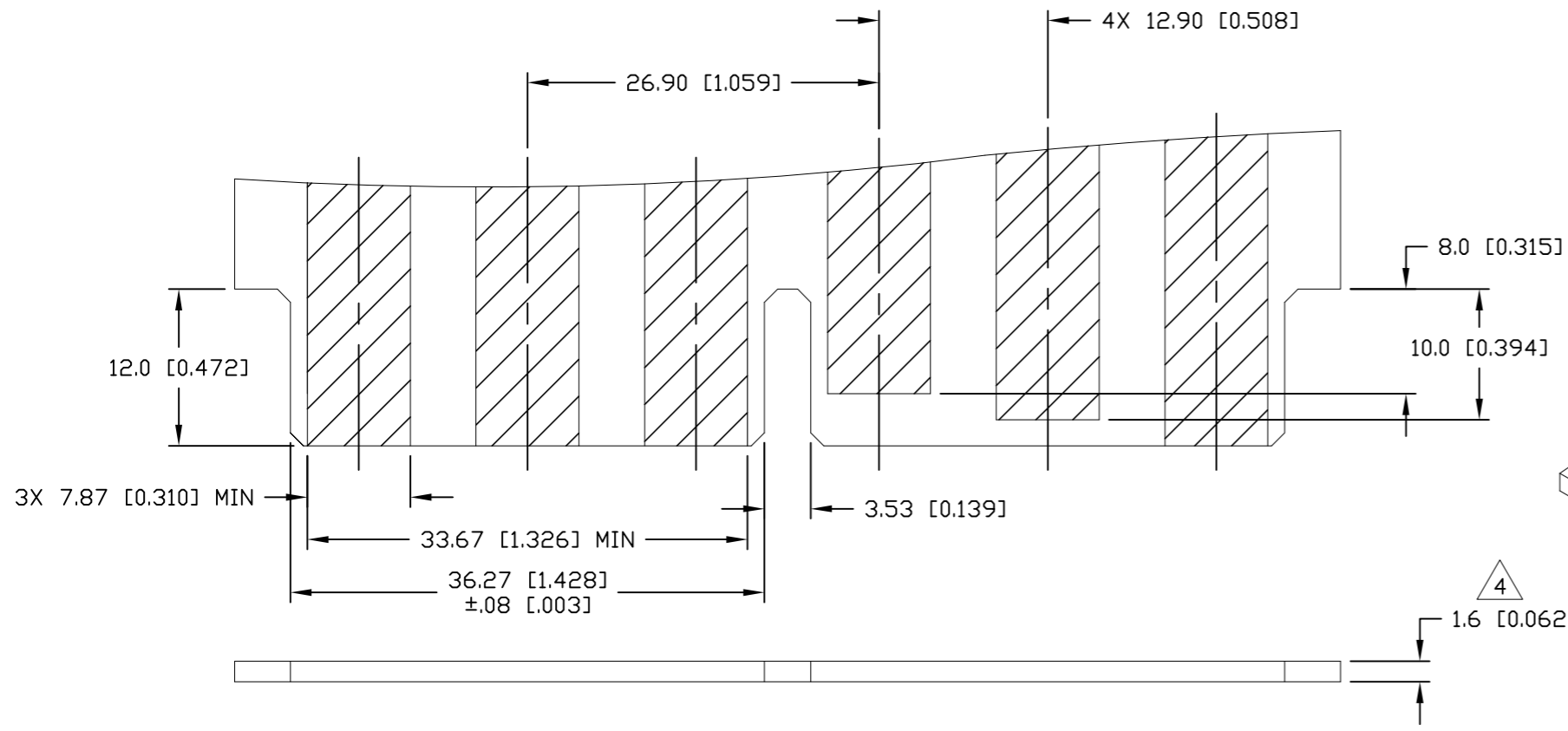

△ 6 DOUBLE SIDED P.C.B. CARD

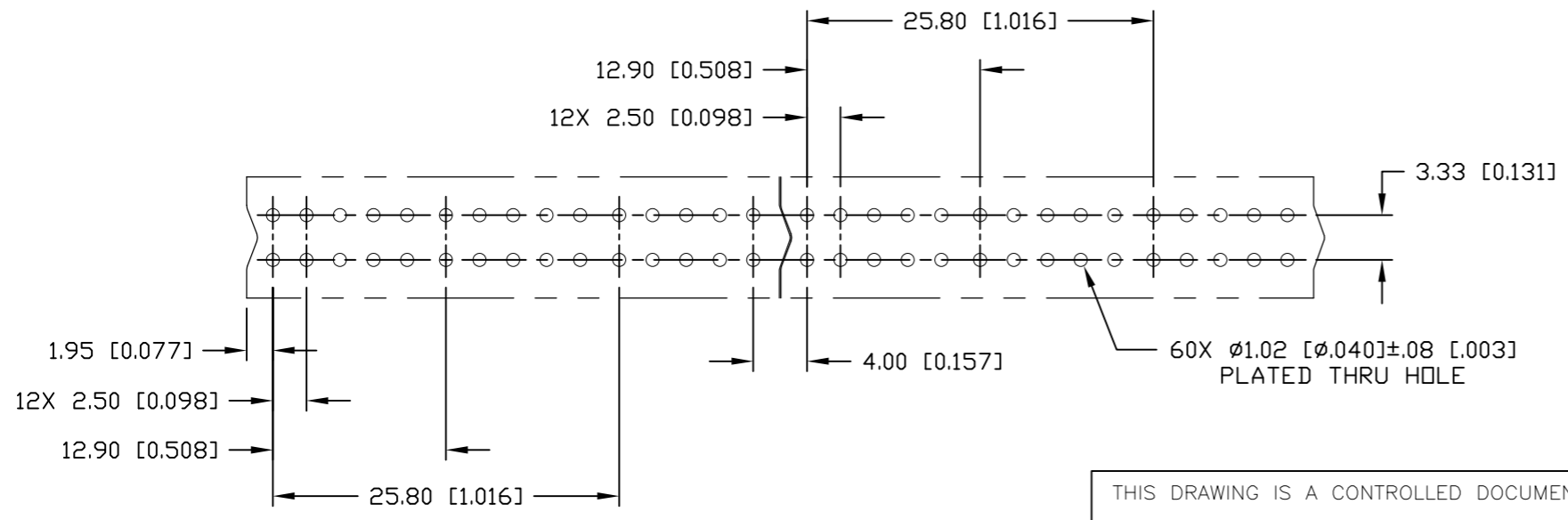
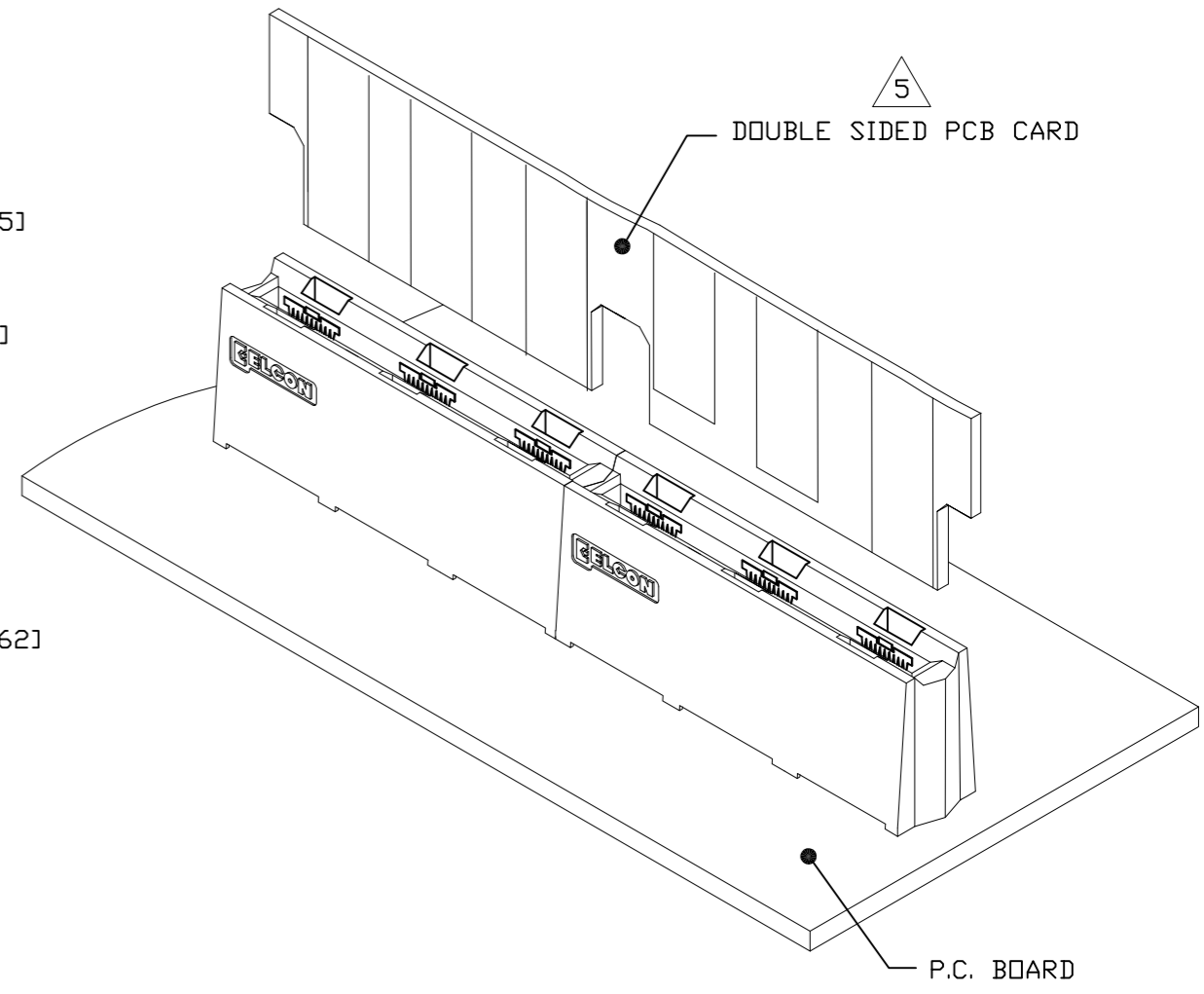

△ 6 RECOMMENDED P.C. BOARD LAYOUT

THIS DRAWING IS A CONTROLLED DOCUMENT.		DWN R. F. A. 01/05/05	TE Connectivity	
DIMENSIONS: mm[INCHES]		CHK -		
TOLERANCES UNLESS OTHERWISE SPECIFIED:		APVD D. CHAU 01/06/05	NAME	
0 PLC ± -		PRODUCT SPEC	RECOMMENDED PCB LAYOUT	
1 PLC ± 0.5[0.020]		APPLICATION SPEC	PN: 286-0052-12101A/-12301A	
2 PLC ± 0.25[0.010]		WEIGHT -	SIZE A3	CAGE CODE 00779
3 PLC ± -		CUSTOMER DRAWING	DRAWING NO C-6650384	RESTRICTED TO -
4 PLC ± -		SCALE 2:1	SHEET 4 OF 5	REV A1
ANGLES ± 0.5°				
FINISH -				

THIS DRAWING IS UNPUBLISHED. RELEASED FOR PUBLICATION
 © COPYRIGHT - By - ALL RIGHTS RESERVED.

LOC	DIST	REVISIONS					
		P	LTR	DESCRIPTION	DATE	DWN	APVD
-	-	-	-	SEE SHEET 1	-	-	-

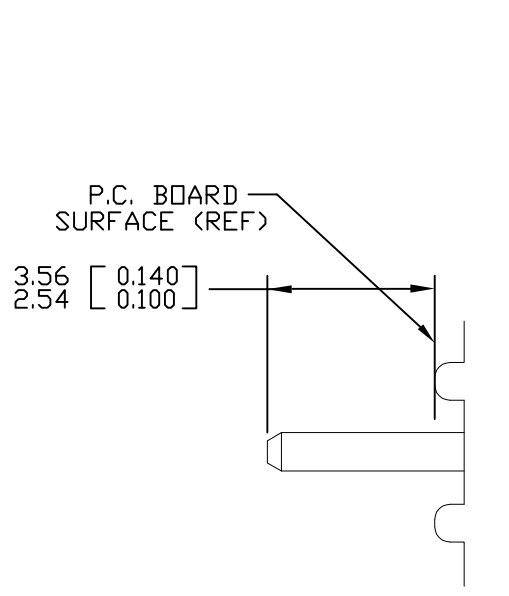

SOLDER PIN DETAIL

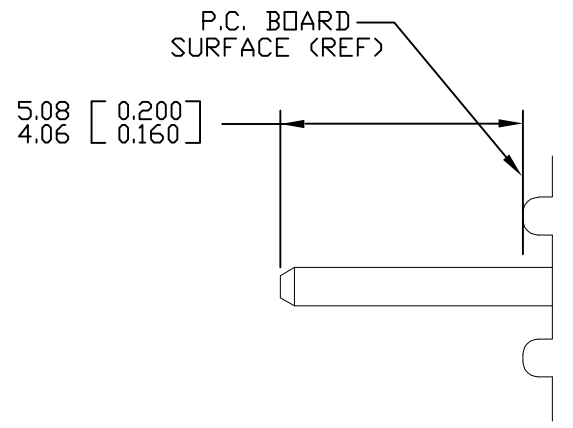

SOLDER PIN DETAIL

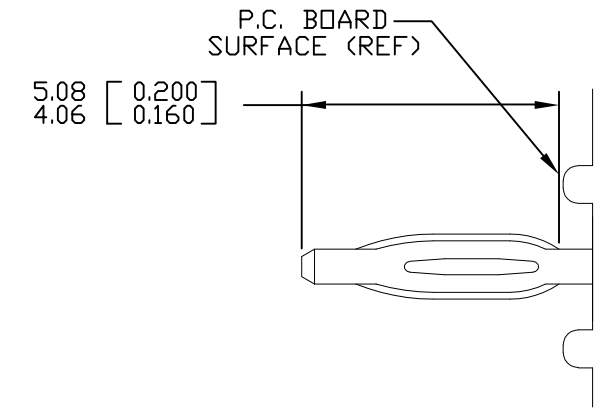

COMPLIANT PIN DETAIL

INSERTION/EXTRACTION FORCES
 MAXIMUM PUSH-IN: 133.3N PER PIN [30 LBS]
 MINIMUM PUSH-OUT: 44.4N PER PIN [10 LBS]

RECOMMENDED PRINTED CIRCUIT HOLE

FINISHED HOLE: $\phi 1.02$ [.040] ± 0.08 [.003]
 DRILLED HOLE: $\phi 1.15$ [.0453] ± 0.013 [.0005]
 COPPER PLATE: .025 [.0010] MINIMUM (PER SURFACE)
 TIN PLATE: .008 [.0003] MINIMUM (PER SURFACE)

THIS DRAWING IS A CONTROLLED DOCUMENT.		DWN R. F. A.	01/05/05	 TE Connectivity	
DIMENSIONS: mm[INCHES]		CHK -	-		
TOLERANCES UNLESS OTHERWISE SPECIFIED:		APVD D. CHAU	01/06/05	NAME	
0 PLC $\pm -$ 1 PLC ± 0.5 [0.020] 2 PLC ± 0.25 [0.010] 3 PLC $\pm -$ 4 PLC $\pm -$ ANGLES $\pm 0.5^\circ$		PRODUCT SPEC		SOCKET CONNECTOR, CROWN EDGE USER INFORMATION	
MATERIAL		APPLICATION SPEC		SOLDER & COMPLIANT TAILS TERMINATION	
FINISH		WEIGHT		SIZE	RESTRICTED TO
-		-		A3	-
		CUSTOMER DRAWING		CAGE CODE	DRAWING NO
				00779	6650384
		SCALE		SHEET	REV
		2:1		5 OF 5	A1